

Linear actuators UBA Series and UAL Series

4.6 ORDERING CODE

UBA	4	RN2	C300	FO	—	FCM
1	2	3	4	5	6	7

SP encoder ...	8
----------------	---

AC 3-phase brake-motor 0.75 kW 4-pole 230/400 V 50 Hz IP 55 Ins. F	W
9.A	9.B

1	Actuator series UBA or UAL	
2	Actuator size 1, 2, 3, 4, 5	pages 128 ... 129
3	Ratio RV1, RN1, RL1 RV2, RN2, RL2	pages 128 ... 129
4	Stroke code C100, C200, C300, C400, C500, C600, C700, C800 (special stroke available on request)	
5	Front attachment BA - standard head with threaded bore ROE - rod end FO - clevis end TS - ball joint FL - flange end TF - hinged head	pages 136 ... 145
6	Position of front and rear actuator attachment STANDARD (without code) or RPT 90°	page 146
7	Stroke end switches FCM-NC - magnetic reed switches, normally closed FCM-NO - magnetic reed switches normally open FCP - inductive proximity switches	pages 147 ... 148 pages 147 ... 148 page 149
8	Accessories SP - rear bracket FI - intermediate support flange AR - anti-turn device MS - safety nut for push load B - bellows encoder - EH 53 or according to required specifications	pages 136 ... 145 page 146 page 150 page 150 page 151 page 151
9.A	Motor data	pages 200 ... 201
9.B	Motor terminal box position	page 146
10	Other specifications example: push rod in stainless steel AISI 303 example: lubricant for low temperature	
11	Filled in SELECTION DATA sheet	page 147
12	Application layout	

APPLICATION: _____

REQUIRED STROKE: _____ mm

REQUIRED LINEAR SPEED: _____ mm/s _____ mm/min _____ m/min TIME TO PERFORM 1 STROKE: _____ s

STATIC LOAD: PULL: _____ N PUSH: _____ N at STROKE _____ mm

DYNAMIC LOAD: PULL: _____ N PUSH: _____ N at STROKE _____ mm

ACTUATOR SUBJECTED TO VIBRATIONS NOT SUBJECTED TO VIBRATIONS

OPERATING: _____ cycle / hour _____ working hours / day Notes: _____

REQUIRED LIFETIME: _____ cycle _____ hours _____ calendar days Notes: _____

ENVIRONMENT: TEMPERATURE _____ °C DUST HUMIDITY _____ % AGGRESSIVE AGENT _____

Ball screw actuators **UBA Series** Acme screw actuators **UAL Series**

Size: 1 2 3 4 5

Ratio: RV2 RV1 RN2 RN1 RL2 RL1

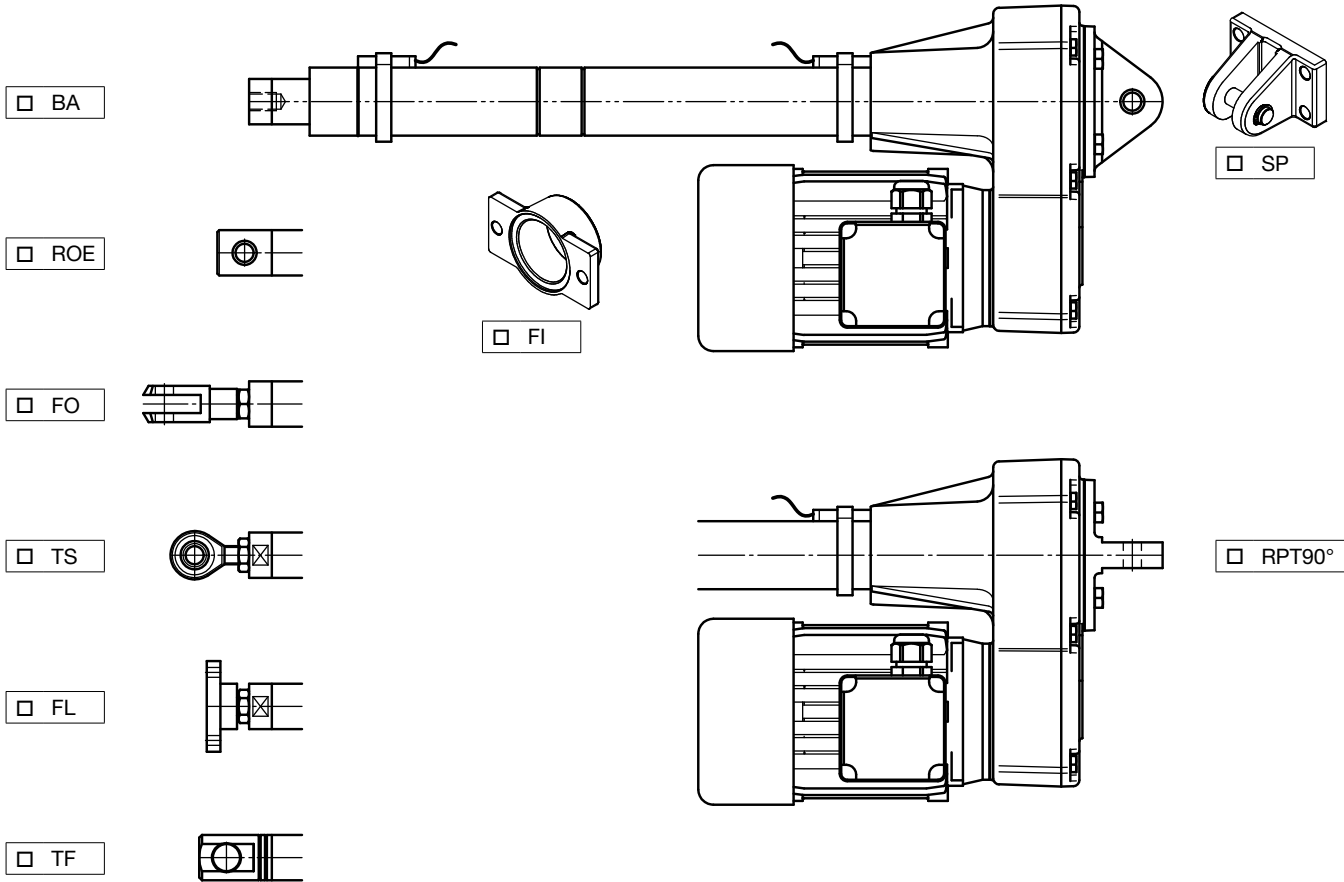

ELECTRIC MOTOR AC 3-phase AC 1-phase DC 24 V or 12 V WITHOUT BRAKE WITH BRAKE

STROKE END SWITCHES ELECTRIC FCE MAGNETIC FCM PROXIMITY FCP

ROTARY ENCODER

ANTI-TURN DEVICE AR SAFETY NUT MS

BELLOWS PUSH ROD IN STAINLESS STEEL OUTER TUBE IN STAINLESS STEEL

OTHER: _____